

# B16.47 Series A Class 400 Weld Neck & Blind

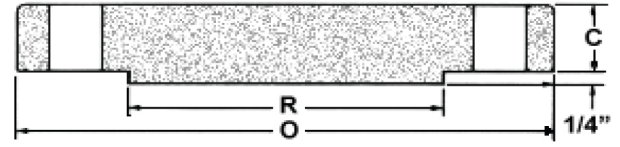
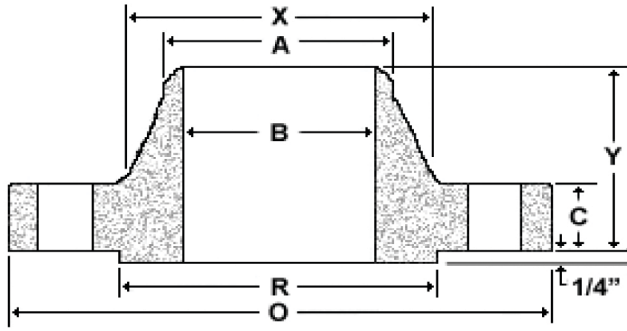

**Weld Neck**

Nom Size	Thickness			Drilling									Weight	
	OD	Weld Neck	Blind	OD of RF	Dia at Base	Bore	LTH	Dia Bevel	Bolt Circle	Bolt Length	Hole Dia	# of Holes	Weld Neck	Blind
	O	C	C	R	X		Y	A		(1)	(2)			
26	38.25	3.50	3.88	29.50	28.62	To be specified by Purchasr.	7.62	26.00	34.50	12.50	1.88	28	650	1263
28	40.75	3.75	4.12	31.50	30.81		8.12	28.00	37.00	13.25	2.00	28	785	1522
30	43.00	4.00	4.38	33.75	32.94		8.62	30.00	39.25	14.00	2.12	28	905	1802
32	45.25	4.25	4.56	36.00	35.00		9.12	32.00	41.50	14.25	2.12	28	1065	2077
34	47.50	4.38	4.81	38.00	37.19		9.50	34.00	43.50	14.75	2.12	28	1200	2415
36	50.00	4.50	5.06	40.25	39.38		9.88	36.00	46.00	15.00	2.12	32	1340	2815
38	47.50	4.88	4.88	40.75	39.50		8.12	38.00	44.00	14.75	1.88	32	935	2450
40	50.00	5.12	5.12	43.00	41.50		8.50	40.00	46.25	15.50	2.00	32	1090	2848
42	52.00	5.25	5.25	45.00	43.62		8.81	42.00	48.25	15.75	2.00	32	1190	3159
44	54.50	5.50	5.50	47.25	45.62		9.18	44.00	50.50	16.50	2.12	32	1375	3635
46	56.75	5.75	5.75	49.50	47.75		9.62	46.00	52.75	17.00	2.12	36	1525	4120
48	59.50	6.00	6.00	51.50	49.88		10.12	48.00	55.25	18.00	2.38	28	1790	4726
50	61.75	6.19	6.25	53.62	52.00		10.56	50.00	57.50	18.50	2.38	32	1950	5303
52	63.75	6.38	6.44	55.62	54.00		10.88	52.00	59.50	18.75	2.38	32	2125	5823
54	67.00	6.69	6.75	57.88	56.12		11.38	54.00	62.25	20.00	2.62	28	2565	6742
56	69.00	6.88	6.94	60.12	58.25		11.75	56.00	64.25	20.25	2.62	32	2710	7352
58	71.00	7.00	7.12	62.12	60.25		12.06	58.00	66.25	20.50	2.62	32	3230	7986
60	74.25	7.31	7.44	64.38	62.38		12.56	60.00	69.00	21.75	2.88	32	3820	9126

Dimensions are in inches. Weights are in pounds.

(1) Bolt lengths are calculated based on bolting one WN to one blind.

(2) Bolt diameter should be 1/8" less than the bolt hole diameter.

**Note:**

Larger sizes as well as intermediate sizes can be furnished.

**Mr. Bhavesh Choudhary**

**+91 9619344811 / +91 9869161792**

**remibhavesh@gmail.com**

**www.remitubes.com**